

ArcWeld 4.5

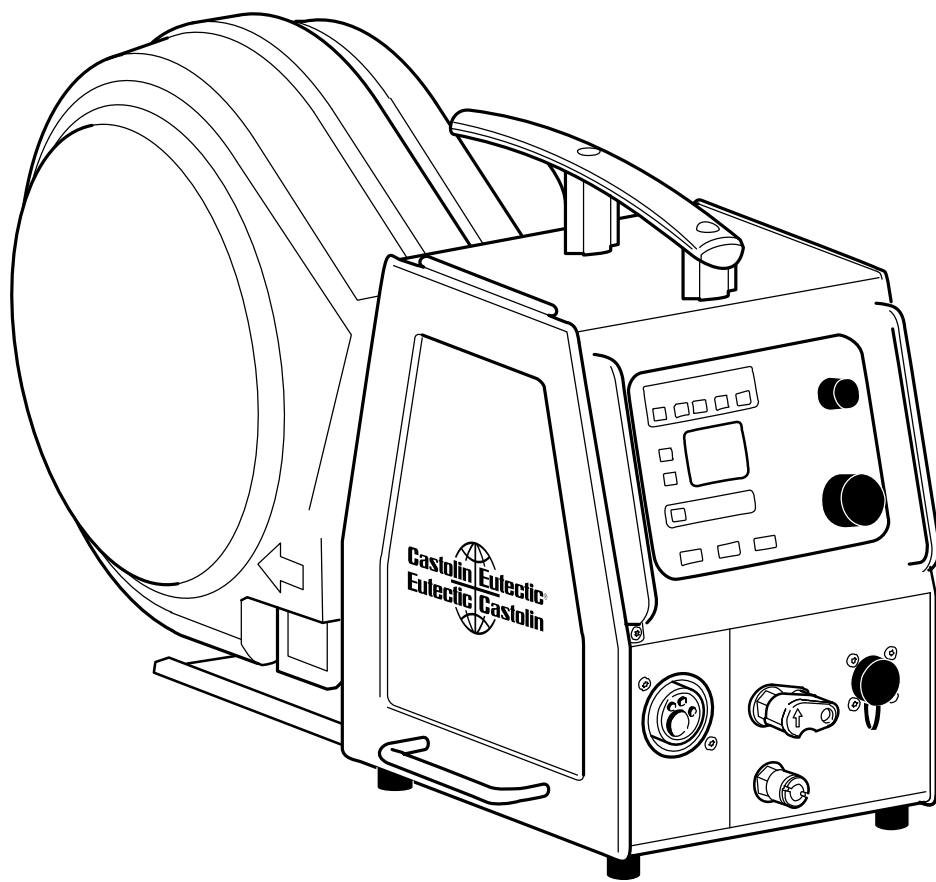

Manual /
TÉCNICO

ArcWeld 4.5

C = component designation in the circuit diagram

Item	Qty	Ordering no.	Denomination	Notes	C
HA1	1	0459 119 001	Handle		
HA2	1	0458 950 001	Sign		
HA3	1	0459 069 004	Side panel		
HA4	1	0459 773 889	MMC module	Panel MA23. See separate spare parts list	
HA5	1	0459 773 886	MMC module	Panel MA24. See separate spare parts list	
HA6	5	0458 544 001	Insulating nut		
HA7	1	0460 523 002	Front plate	For unit with water conn. and single front connector	
	1	0458 680 002	Front plate	For unit with water conn. and double front connector	
HA8	1	0460 523 001	Front plate	For unit without water conn. and single front connector	
	1	0458 680 001	Front plate	For unit without water conn. and double front connector	
HA9	2	0192 230 105	Cover plug		
H10	1	0365 803 017	Quick connection	Female, blue	
H11	1	0365 803 016	Quick connection	Female, red	
HA12	1	0456 496 002	Hose, blue	L=0.33, Ø 9/5mm, to be ordered per metre	
HA13	1	0456 496 001	Hose red	L=0.33, Ø 9/5mm, to be ordered per metre	
HA14	7		Hose clamp	Ø 11.3/10.8	
HA15	1		Water outlet with lock	For further information see page 11.	13S1
HA16	3	0458 777 001	Protection clamp		
HA17	1	0192 526 002	Sealing strip	L=1.34	
HA18	1		Wire feed mechanism	For ArcWeld 4.5, see page 8.	
HA19	2		Nut	M6	
HA20	4	0153 043 002	Insulating washer		
HA21	1	0459 256 001	Insulating plate		
HA22	2		Screw	M6x20	
HA23	1	0459 069 003	Side panel		
-		0459 213 001	Label for side panel		
HA24	1	0459 547 001	Locking device		
HA25	3	0458 777 002	Protection clamp	Handle	
HA26	1	0458 535 890	MMC module	Panel U6. See separate spare parts list	
HA27	1	0458 535 887	Cover plate MMC space		
HA28	1	0449 491 001	Sticker, synergic lines	Only for MA24, valid from software version 1.12 to 1.25	
	1	0449 491 002	Sticker, synergic lines	Only for MA24, valid from software version 1.26	

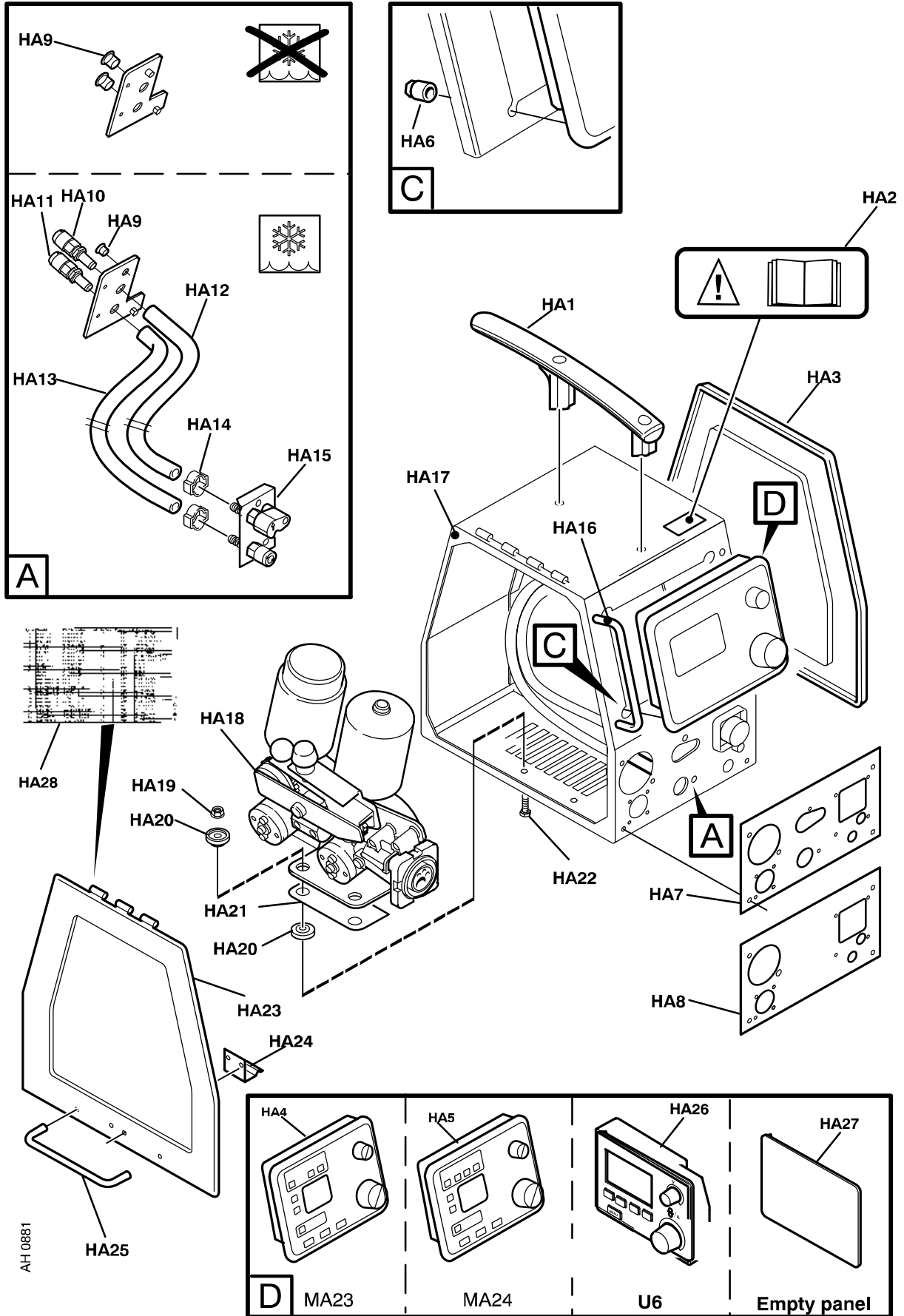

ArcWeld 4.5

C = component designation in the circuit diagram
(W) = wear part

Item	Qty	Ordering no.	Denomination	Notes	C
HB1	1	0459 071 884	Cover		
HB2	1	0459 099 001	Middle plate		
HB3	1	0458 662 880	Bottom plate		
HB4	1	(W)	Inlet nozzle		
HB5	1	0458 748 001	Insulating bushing		
HB6	1	0458 748 002	Insulating washer		
HB7	1		Nut	M 10	
HB8	4	0467 695 001	Rubber foot	Ø 20/6.4x3, When ordering: 4 pieces delivered.	
HB9	1	0160 609 881	Welding current terminal		
HB10	1	0459 102 002	Rear plate		
HB11	1	0466 325 001	Gasket		
HB12	1		Spacer ring	Included in item HB9	
HB13	1		Washer	Included in item HB9	
HB14	1		Nut	Included in item HB9	
HB15	1	0460 942 001	Bar flexible		
HB16	1	0467 911 881	Capacitor		13C4
HB17	1		Washer	Ø 22/10.5x2	
HB18	2		Spring washer	Ø 20/10.2x1.1	
HB19	1		Screw	M10x20	
HB20	6		Nut	M3	
HB21	4	0456 686 880	Clamp		
HB22	2	0467 911 884	Capacitor	0.1 µF 250V	13C2, 13C3
HB23	2		Washer lock	3.2x6 ST	
HB24	1	0538 500 110	Panel plug	10 pole	13XP1
HB25	2	0459 854 001	Insulation		
HB26	2	0455 516 001	Protection cap		
HB27	8		Screw	6-19x8	
HB28	1	0193 054 007	Solenoid valve	with quick connection	13YV1
HB29	1		Hose clamp	11.3/10.8	
HB30	1	0456 496 001	Hose red	L=0.50, Ø9/5mm, to be ordered per metre	
HB31	1	0538 500 111	Panel socket	10 pole	13XS15
HB32	4	0194 019 005	Spacer		
HB33	1	0487 187 890	PC-board	The circuit board must be configured when installed	13AP1
	1	0487 187 884	PC-board	Circuit board configured for ArcWeld 4.5	13AP1
HB34	2	0456 686 880	Clamp		
HB35	2	0467 911 884	Capacitor		13C2, 13C3
HB36	1	0486 388 880	Circuit board		13AP2
HB37	1	0193 260 153	Connector		13XS11
HB38	1	0458 681 880	Cable	Connector 13XS9, ferrite rings 13L2 and 13L3 included.	
HB39	1	0457 799 001	Screen plate		
HB40	1	0457 801 001	Insulation		
HB41	1	0458 681 882	Cable	Cable between 20AP1 and MMC unit, cable connectors are included	13XP14, 13XS14

For wear parts see page 12.

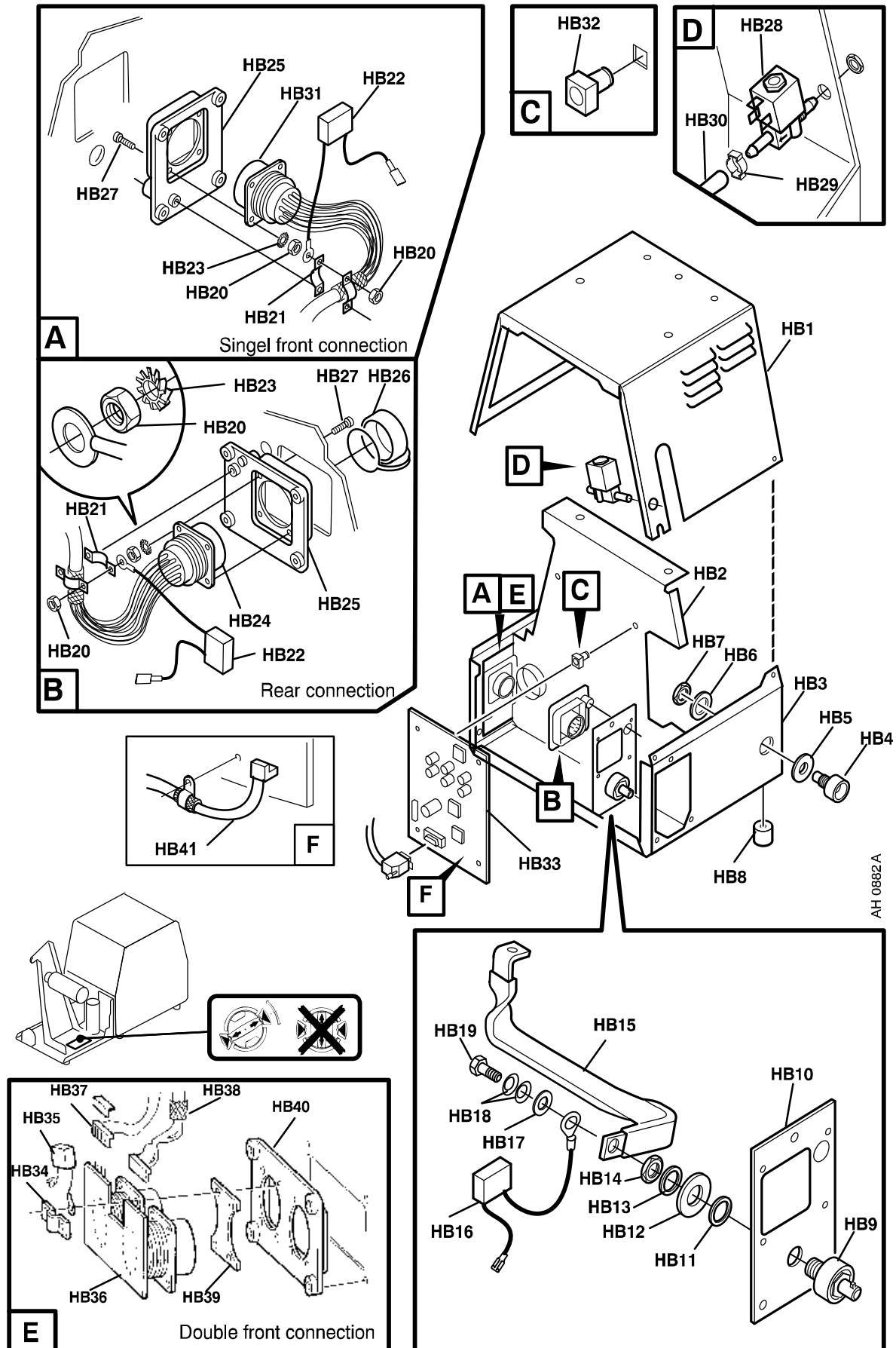

ArcWeld 4.5

C = component designation in the circuit diagram

(W) = wear part

Item	Qty	Ordering no.	Denomination	Notes	C
HD1	1	0458 547 880	Wire feed mechanism	Type MEL 48	13M2, 13G1
-	1	0156 728 012	Drive unit	With pulse generator	
-	1	0193 260 063	Connector	4 pole	
HD2	1	0156 728 011	Drive unit		13M3
	1	0191 548 010	Flat pin		
	6		Nut	M8	
HD3	1	0467 911 880	Capacitor	0.1 µF 250V with cable lugs	13C6
HD4	1		Screw	M6X40	
HD5	1		Washer	Ø 6.4/12x1.5	
HD6	1	0455 048 001	Insulating tube		
HD7	1	0458 545 001	Connection housing		
HD8	9		Screw	M5X20	
HD9	1		Screw	M6X16	
HD10	1		Nut	M6	
HD11	1	0455 047 001	Front flange		
HD12	1	0455 044 001	Current connection		
HD15	1	(W)	Outlet nozzle		
HD16	2	(W)	Feed roller		
HD17	4	0156 707 001	Distance washer		
HD18	2	0156 707 002	Adjustement spacer		
HD19	2	0366 944 001	Washer		
HD20	2		Screw	M5x16	
HD21	1	(W)	Bogey		
HD23	1	0366 961 001	Inter nozzle support		
HD24	2	0215 702 708	Locking washer		
HD25	1	(W)	Intermediate nozzle		
HD26	1		Wire feed plate		
HD27	1	0366 962 001	Bogey axle		
-	1		Screw	M8X30	
-	1		Washer	Ø 26/8.4X5	
HD29	2	0368 750 001	Insulating sleeve	For cable set	
	1	0459 229 880	Cable set		
HD30	1		Screw	M8x25	
HD31	1		Washer	Ø 16/8.4x1.5	
HD32	1		Belleville washer	Ø 16/8.2x0.9	
HD33	1		Nut	M6	

For wear parts see page 14.

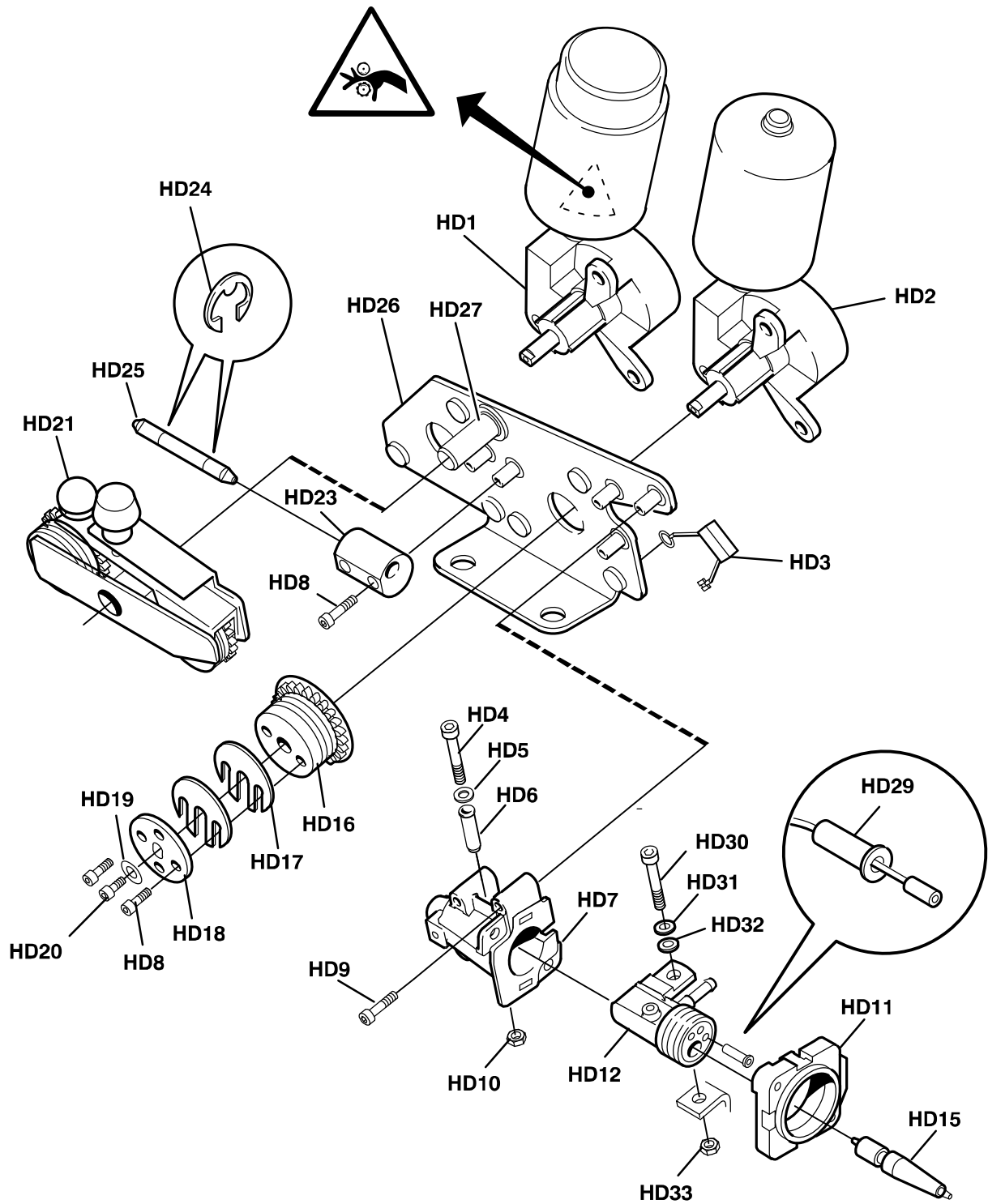

AH 0883

ArcWeld 4.5

Item	Qty	Ordering no.	Denomination	Notes
HE3	1	0458 674 880	Bobbin cover	
HE4	1	0146 967 881	Brake hub	
HE5	1	0459 294 881	Spool attachment	
HE6	1	0156 633 003	Reel cover	

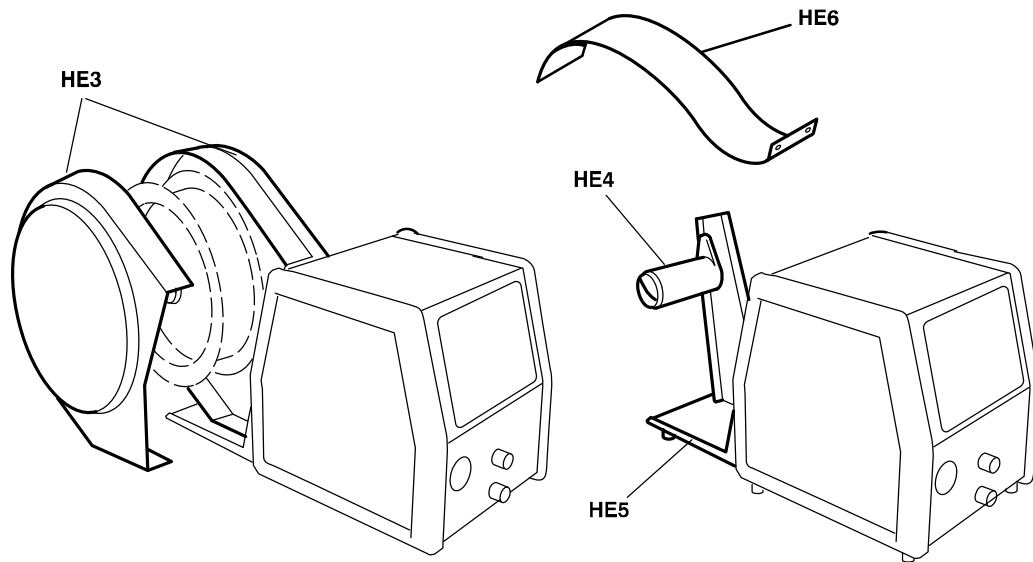

ArcWeld 4.5

Item	Qty	Ordering no.	Denomination	Notes
HF1	1		Nut	M5
HF2	1		Washer	D16/5x1
HF3	1		Spring	
HF4	1		Water lock cam	
HF5	1	0365 803 015	Quick connector	Female, blue
HF6	1		Water lock bushing	
HF7	1		Water lock outlet	
HF8	1		Screw	M5x35
HF9	1		Nut	M3
HF10	1	0458 589 001	Insulation plate	
HF11	1	0458 364 001	Micro switch	
HF12	1	0365 803 014	Quick connector	Female, red
HF13	2		Screw	M3x20
HF14	2		Nut	M3

SPARE PARTS SET

Item	Qty	Ordering no.	Denomination	Notes
HF50	1	0458 370 900	Water connection spare kit	Contains items HF1, HF2, HF3, HF4, HF6, HF7 and HF8

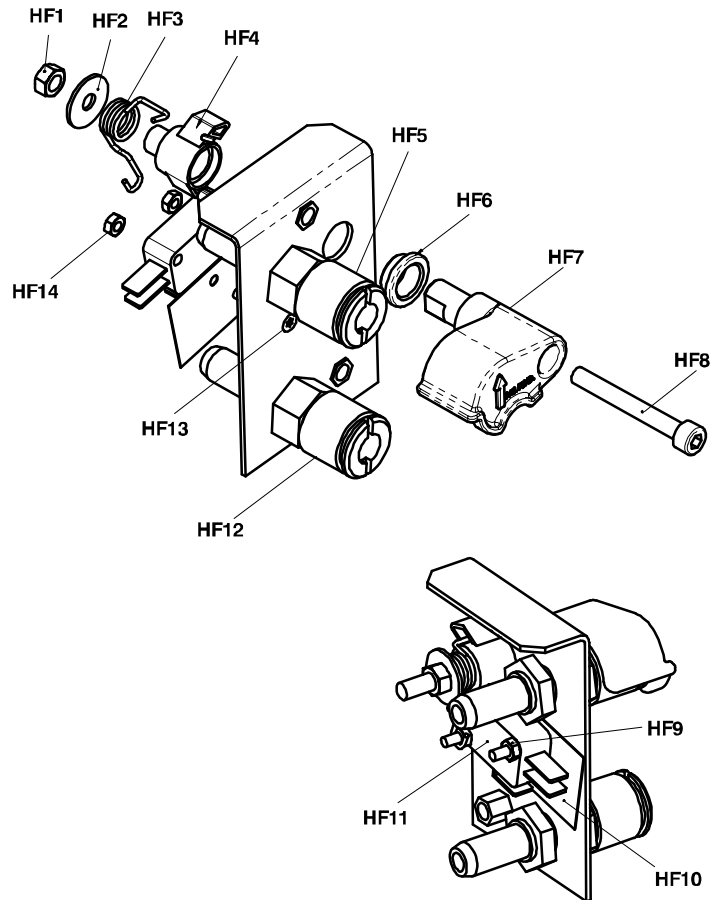

H

ArcWeld 4.5

Item	Ordering no.	Denomination	Wire type	Wire dimensions
HK1	0469 837 880 0469 837 881 0469 837 882	Outlet nozzle Outlet nozzle Outlet nozzle	Fe, Ss & cored Al Fe, Ss & cored	Ø 2.0 mm steel for 0.6-1.6 mm Ø 2.0 mm plastic for 1.0-1.6 mm Ø 3.4 mm steel for 2.0-2.4 mm

Item	Ordering no.	Denomination	Wire type	Wire Ø mm	Groove 1	Groove 2	Groove 3	Groove typ	Roller / Bogey markings
HK2	0366 966 880	Feed Roller	Fe, Ss & cored	0.6-1.2	0.6-0.8	0.9-1.0	1.2	V	1
	0366 966 888	Feed Roller	Fe, Ss & cored	0.9	0.9	0.9	0.9	V	.035
	0366 966 881	Feed Roller	Fe, Ss & cored	1.4-1.6	1.4-1.6	2.0	2.4	V	2
	0366 966 890	Feed Roller	Fe, Ss & cored	1.6	1.6	1.6	1.6	V	1/16
	0366 966 889	Feed Roller	Fe, Ss & cored	1.2	.045 / 1.2	.045 / 1.2	.045 / 1.2	V	.045 / 7
	0366 966 900	Feed Roller	Fe, Ss & cored	0.9-1.6	0.9-1.0	1.2	1.4-1.6	V	6
	0366 966 893	Feed Roller	Cored	1.2	1.2	1.2	1.2	V-Knurled	.045
	0366 966 882	Feed Roller	Cored	1.2-2.0	1.2	1.4-1.6	2.0	V-Knurled	3
	0366 966 894	Feed Roller	Cored	1.6	1.6	1.6	1.6	V-Knurled	1/16
	0366 966 883	Feed Roller	Cored	2.4	2.4	not used	not used	V-Knurled	4
	0366 966 885	Feed Roller	Al	1.2	1.2	1.2	1.2	U	U2
	0366 966 899	Feed Roller	Al	1.0-1.6	1.0	1.2	1.6	U	U4

Item	Ordering no.	Denomination	Notes
HK3	0156 707 001	Distance washer	
HK4	0156 707 002	Adjustment spacer	
HK5		Screw	M5x20
HK6		Screw	M5x16

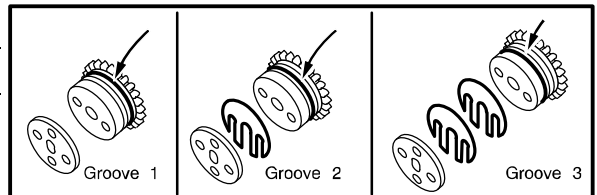

HD = Heavy Duty

Item	Ordering no.	Denomination	Wire type	Wire dimensions	Groove typ	Roller / Bogey markings
HK7	0366 902 880	Bogey (HD)	Fe, Ss & cored	Ø 0.6 - 1.2 mm	V	1
	0366 902 902	Bogey (HD)	Fe, Ss & cored	Ø 0.9	V	.035
	0366 902 900	Bogey (HD)	Fe, Ss & cored	Ø 0.9 - 1.6 mm	V	6
	0366 902 881	Bogey (HD)	Fe, Ss & cored	Ø 1.4 - 2.4 mm	V	3
	0366 902 894	Bogey (HD)	Fe, Ss & cored	Ø 1.2 mm	V	.045 / 7
	0366 902 901	Bogey (HD)	Fe, Ss & cored	Ø 1.6 mm	V	1/16
	0366 902 903	Bogey (HD)	Cored	Ø 1.2 mm	V-Knurled	.045
	0366 902 882	Bogey (HD)	Cored	Ø 1.2 - 2.0 mm	V-Knurled	3
	0366 902 904	Bogey (HD)	Cored	Ø 1.6 mm	V-Knurled	1/16
	0366 902 883	Bogey (HD)	Cored	Ø 2.4 mm	V-Knurled	4
	0366 902 899	Bogey (HD)	Al	Ø 1.0 - 1.6 mm	U	U4
	0366 902 886	Bogey (HD)	Al	Ø 1.2 mm x 3	U	-

Item	Ordering no.	Denomination	Wire type	Wire dimensions
HK8	0366 944 001	Washer		
HK9	0156 603 001	Intermediate nozzle	Fe, Ss & Al	Ø 2 mm plastic for 0.6-1.6 mm
	0156 603 002	Intermediate nozzle	Fe, Ss & Al	Ø 4 mm plastic for 2.0-2.4 mm
	0332 322 001	Intermediate nozzle	Cored	Ø 2.4 mm copper for 1.2-2.0 mm
	0332 322 002	Intermediate nozzle	Cored	Ø 4 mm copper for 2.4 mm

Item	Ordering no.	Denomination	Note
HK10	0215 702 708	Locking washer	
HK11		Nut	M10
HK12	0458 748 002	Insulating washer	
HK13	0458 748 001	Insulating bushing	

ArcWeld 4.5



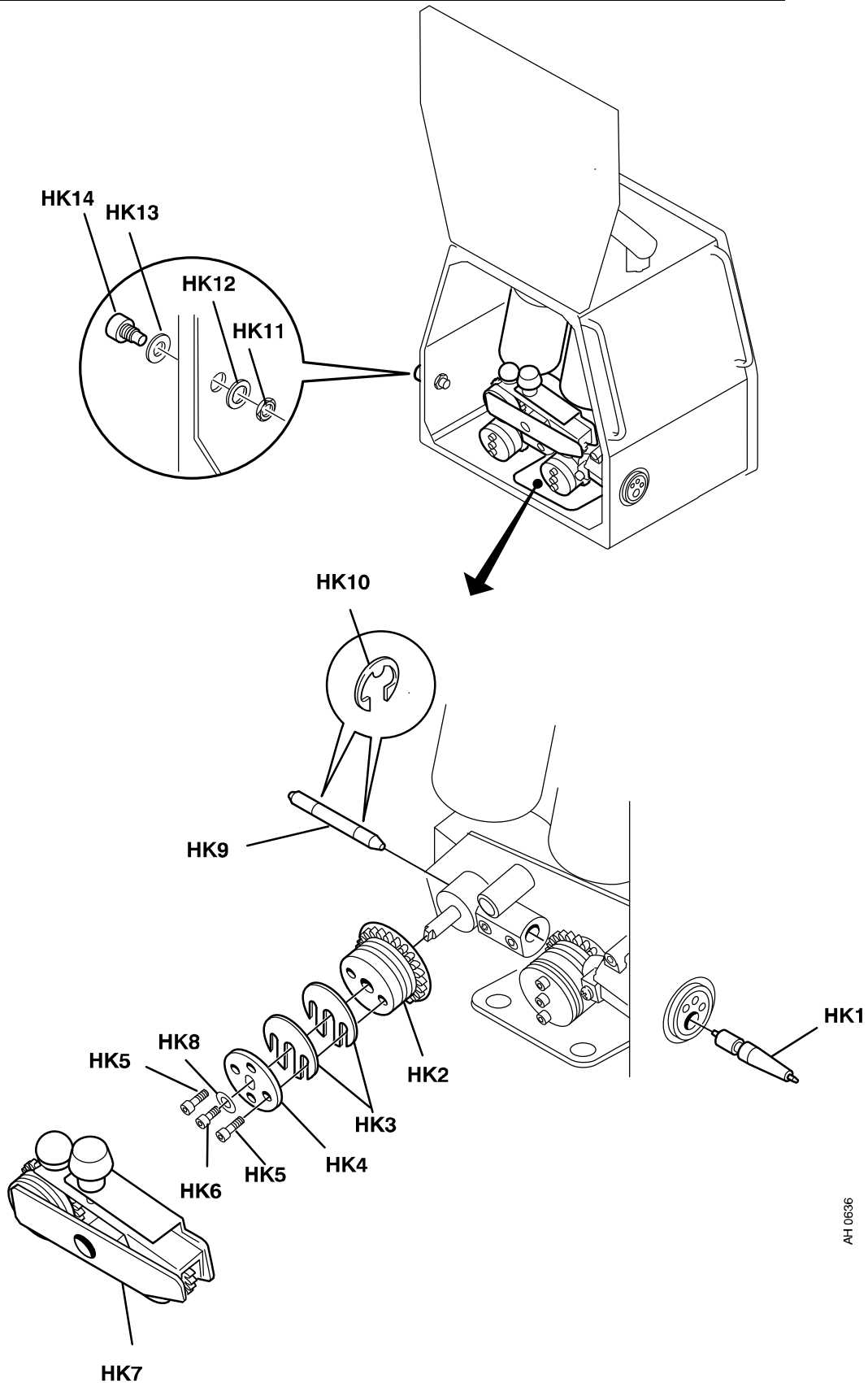

Item	Ordering no.	Denomination	Wire type	Wire dimensions
HK14	0156 602 001	Inlet nozzle	Fe, Ss, Al & Cored	Ø 2 mm plastic for 0.6-1.6 mm
	0156 602 002	Inlet nozzle	Fe, Ss, Al & Cored	Ø 4 mm plastic for 2.0-2.4 mm
	0332 318 001	Inlet nozzle (HD)	Fe, Ss & Cored	Ø 2.4 mm steel for 1.2-2.0 mm
	0332 318 002	Inlet nozzle (HD)	Fe, Ss & Cored	Ø 4 mm steel for 2.4 mm

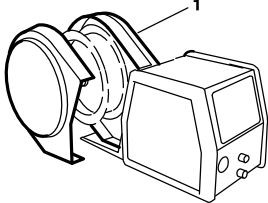
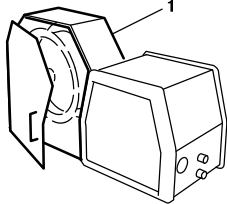
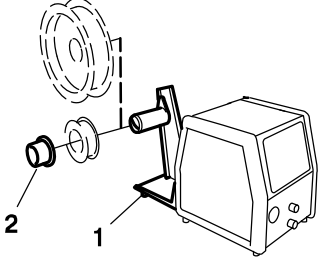
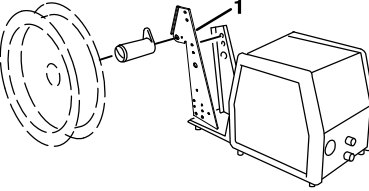
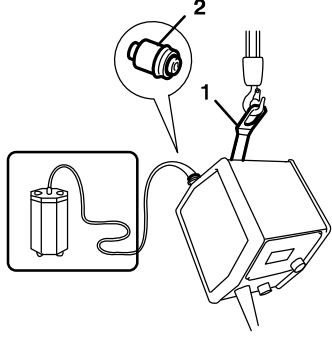
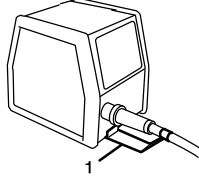

AH 0636

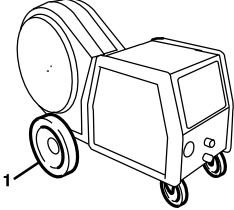
Accessories

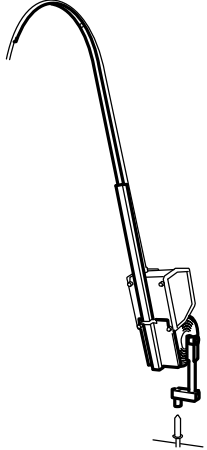
	<p>1 Bobbin cover, plastic 18 kg Ø 300mm 0458 674 880</p>
	<p>1 Bobbin cover, metal 18 kg Ø 300mm 0459 431 880</p>
	<p>1 Bobbin holder 0458 704 880 2 Adapter for 5 kg bobbin 0455 410 001</p>
	<p>1 Adapter for 440 mm bobbin 0459 233 880</p>
	<p>1 Lifting eye 0458 706 880 2 Quick connector SpeedPac F102 440 880</p>
	<p>1 Strain relief for welding gun 0457 341 881</p>

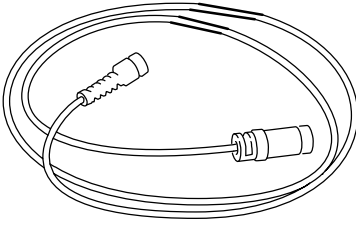
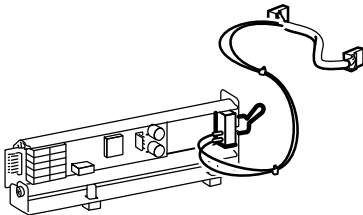
	<p>1 Wheel kit for feed 0458 707 880</p>
	<p>Strain relief bracket for connection set 0459 234 880</p>
	<p>Counter balance device (includes mast and counter balance) for 300 mm bobbin 0458 705 880 for 440 mm bobbin 0458 705 882</p>
	<p>Remote control unit MTA1 CAN 0459 491 880 MIG/MAG: wire feed speed and voltage MMA: current and arc force TIG: current, pulse and background current</p>
	<p>Remote control unit M1 10Prog CAN 0459 491 882 Choice of on of 10 programs MIG/MAG: voltage deviation TIG and MMA: current deviation</p>
	<p>Remote cable CAN 4 pole - 10 pole 5 m0459 960 880 5 m HD0459 960 980 Remote cable CAN 4 pole - 12 pole only for empty panels together with Controle ArcWeld 5 m0459 554 880 5 m HD0459 554 980</p>
	<p>Remote adapter kit For Mig trac / Rail trac 0459 681 880 For MXH 300wPP / MXH 400wPP / PSF RS3 . 0459 681 881</p>

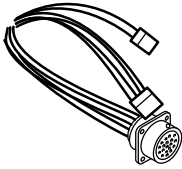
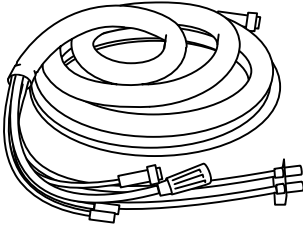
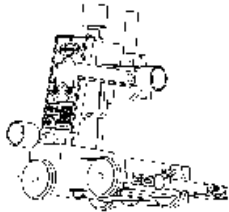
	<p>Connection kit For MXH 300wPP / MXH 400wPP 0459 020 883</p>
	<p>Connection set, 70 mm² 10 pole cable plug - 10 pole cable socket 1.7 m 0459 528 780 5 m0459 528 781 10 m0459 528 782 15 m0459 528 783 25 m 0459 528 784 35 m0459 528 785</p> <p>Connection set water, 70 mm² 10 pole cable plug - 10 pole cable socket 1.7 m 0459 528 790 5 m0459 528 791 10 m0459 528 792 15 m0459 528 793 25 m0459 528 794 35 m0459 528 795</p> <p>Connection set, 95 mm² 10 pole cable plug - 10 pole cable socket 1.7 m 0459 528 980</p> <p>Connection set water, 95 mm² 10 pole cable plug - 10 pole cable socket 1.7 m 0459 528 990</p>
	<p>Mig trac Equipment for mechanized welding More information at the nearest Eutectic agency</p>

ArcWeld 4.5

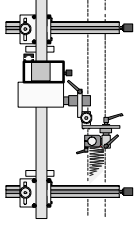
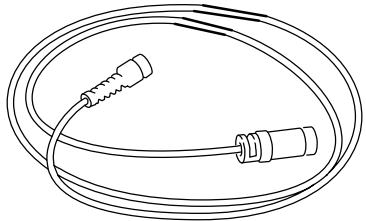
	<p>Rail trac Equipment for mechanized welding</p>	<p>More information at the nearest Eutectic agency</p>
<p>Controle ArcWeld 4.5 0460 820 880</p>		
	<p>Control cable for Controle ArcWeld 4.5 (connectors included) 5 m 0456 280 881 10 m 0456 280 882</p>	

Information on Miggytrack and PSF welding guns can be found in separate brochures.



Eutectic do Brasil Ltda.

Rua Arthur Barbarini, 959 - Distrito Industrial - Indaiatuba - SP - CEP 13347-436 - Tel. 019 3113-2800

- **BELO HORIZONTE:** Tel.: 031-2191-4988 - FAX: 031-2191-4991
- **SERTÃOZINHO:** 016-3521-2350 - FAX: 016-3521-2350

Internet: <http://www.eutectic.com.br>