



**Castolin Eutectic®**  
**Eutectic Castolin**



**OPERATING  
MANUAL**

**GSX 425 ITAIPU**



# GSX 425 ITAIPU

Code: 0704191



**Welding rectifier for  
coated electrodes**



# **GSX 425 ITAIPU**

**Instruction Manual**

**Spare parts list**

## **Contents**

01 - Description.....	4
02 - Safety procedures .....	4
03 - Duty cycle .....	5
04 - Technical characteristics .....	5
05 - Controls and components.....	5
06 - Installation.....	6
07 - Operation .....	7
08 - Maintenance .....	7
09 - Repair.....	7
10 - Electrical diagram.....	8
11 - Spare parts .....	9

## 1 - Description

### 1.1 - General

GSX 425 rectifier is a power source with constant current characteristics projected for welding with coated electrodes using direct current.

Ideal for welding of Carbon steels, alloyed steels, stainless steels, cast Iron, Aluminum and its alloys, Copper and bronze.

Welding current can be continuously adjusted to any application in within utilization range by means of a crank installed on front panel.

Suitable for electrodes up to 6.0mm.

GSX 425 rectifier cabinet offers sound construction and can be easily moved all about working place. Cart is provided with brakeage and lifting devices.

## 2 - Safety procedures

Following care must always be taken prior to start any welding operation:

### Eye protection

Always wear welding helmet with appropriate glass to protect eyes and face (Table 1).

Welding current (A)	Glass n°
30 - 75	8
75 - 200	10
200 - 400	12
over 400	14

**Table 1:** Adequate eye protection in relation to welding current

### Body protection

Insulating leather gloves must always be worn on both hands. For complex jobs requiring high moving and precise electrode holder positioning, wear fine leather gloves. Delicate welding jobs with low current intensity allow use of woven fabric gloves.

Entire body must be protected against ultra-violet rays emitted by the electrical arc.

### Ventilation

Welding should never be performed in completely enclosed spaces without adequate means to exhaust gases and fumes.

### Electrical protection

When handling with any electrical equipment, special care must be taken to avoid contact with "live" parts (that is, which are under tension) without appropriate protection.

Solid, insulating rubber footwear should be worn, even thus do not step on wet ground while welding.

Check electrode holder and cables, they must offer perfect conditions without worn-out, burnt or unthreaded parts.

Equipment must be totally disconnected from mains prior to open cabinet. Ground cable, supplied together with feeding cable, must be permanently connected.

### Fire protection

Paper, straw, wood, woven fabrics, cotton tow and any other flammable material must be removed from welding area. Containers for inflammable material must be thoroughly rinsed and dried, free of any residual vapours.

Chlorinated solvents such as Carbon tetrachloride and trichloretylene, although not inflammable, if not thoroughly dried originate gases of high toxicity when in contact with electrical arc.

**In case of fire or short-circuit, never throw water on any electrical equipment. Immediatly disconnect equipment from mains and use carbonic gas or chemical powder fire extinguisher to eliminate flames.**

### 3 - Duty cycle

Duty cycle is the rate between the period of time a welding equipment can supply a given maximum welding current (load time) and a reference time which, as per international rules, is considered to be 10 minutes.

Nominal duty cycle of 60% means that equipment can repeatedly supply its nominal welding current during periods of 6 minutes (load), each period being followed by a resting period (when equipment does not supply welding current) of 4 minutes (6 + 4 = 10 minutes). Such cycle is repeated without internal components overheating (as per equipment project pre-established limits). Same reasoning applies to any duty cycle value.

In GSX 425 rectifier, allowed duty cycle increases up to 100% as welding current being used decreases; inversely, allowed duty cycle decreases as welding current increases up to maximum range.

### 4 - Technical characteristics

TECHNICAL CHARACTERISTICS			
ABNT class	II		
Current range (A)	45 - 425		
Nominal current (A)	300 @ 60%		
No-load voltage maximum (V)	76		
Permitted loads:			
Duty cycle (%)	230 @ 100%		
Current (A)	230	300	425
Tension (V)	30	32	37
Electrical feeding (V-Hz)	220 / 380 / 440 - 60		
Apparent nominal power (KVA)	24,3		
Thermal class	H (180°C)		
Dimensions (w x l x h - mm)	780 x 950 x 870		
Weight (kg)	185		

**Table 2:** GSX 425 technical characteristics

### 5 - Controls and components

#### 5.1 - Front panel

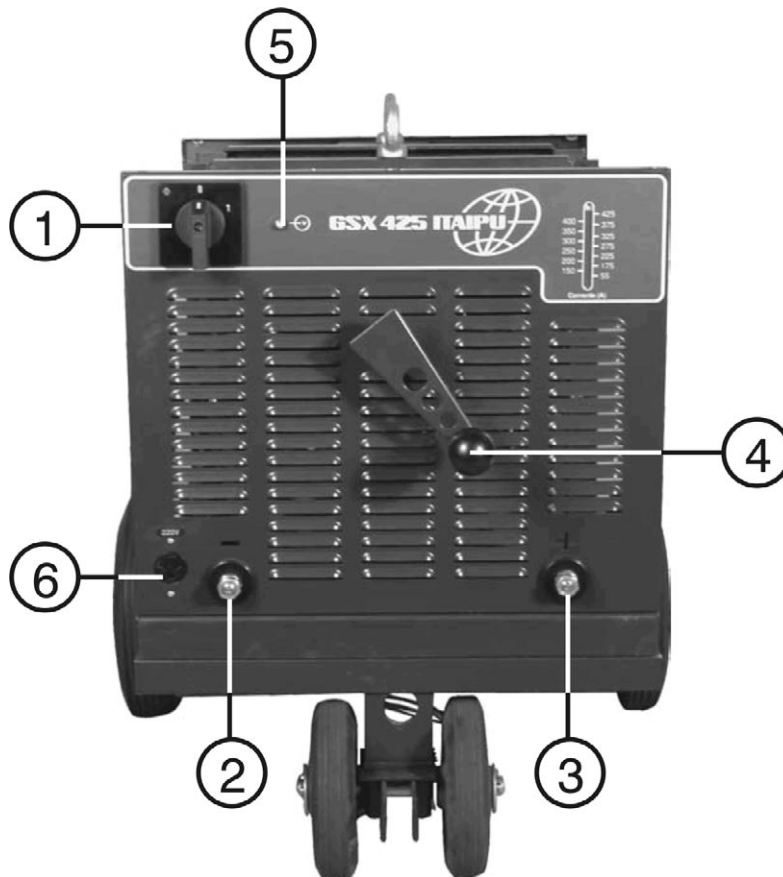

- 1 - On/Off switch = allows operator to switch on and switch off the equipment
- 2 - Negative outlet terminal = for working cable connection
- 3 - Positive outlet terminal = for electrode-holder cable connection
- 4 - Crank = allows welding current value adjustment
- 5 - Pilot lamp = when lit on indicates that equipment is energized
- 6 - Auxiliar socket 220V = for auxiliar equipment feeding

**Obs.:** Crank scale graduation is a reference for current range

## 6 - Installation

### 6.1 - Reception

When receiving a GSX 425 rectifier, you should remove all packaging material involving the equipment and check for eventual damages which could have occurred during transportation. Any complaint related to damages occurred during transportation should be directed to the transporter company.

All material that could obstruct refrigerating air circulation must be removed.

### 6.2 - Working area

A free space of at least 700mm should be left all around GSX 425 rectifier in order to allow its adequate ventilation as well as to permit proper operation and easy access in case of preventive or corrective maintenance.

Installation of any air filtering device reduces available refrigeration air volume and can generate internal components overheating.

Installation of any filtering device not authorized by supplier, cancels equipment warranty.

### 6.3 - Electrical feeding

Electrical feeding tension requirements

are mentioned on the nominal plate. GSX 425 is projected to operate in triphasis mains of 220, 380 or 440 V, 60 Hz.

For a GSX 425 rectifier electrical feeding, the feeding cable supplied together with the equipment can be used (4 conductors being 3 for feeding and 1 for grounding). Or an appropriate cable with diameter corresponding to desired length and with 4 conductors, being 3 for feeding and 1 for grounding. In any case, electrical feeding must be done through an exclusive wall-switch with fuses or protective circuit-breakers adequately dimensioned.

Table below indicates cables and fuses dimensioning:

Feeding tension (V)	Consumption at nominal load (A)	Feeding conductors (Copper - mm <sup>2</sup> )	Retarding fuses (A)
220	64	10	80
380	38	10	50
440	32	10	40

**Table 3:** Cables and fuses dimensioning

GSX 425 rectifier is supplied to be connected to a 440 V feeding system. In case feeding tension is different, primary connections should be adapted as indicated in the electrical diagram. Remotion of left cabinet lateral allows direct access to the set of primary connections terminals.

### Important!

Grounding terminal is connected to GSX 425 rectifier chassis. It should be connected to an efficient grounding point of the general electrical installation. Do not connect grounding conductor of feeding cable to any on-off switch terminals because such procedure would generate electrical tension on equipment chassis.

All electrical connections must be well fastened in order to eliminate risks of sparking, overheating or tension dropping in circuits.

**Do not use electrical system “neutral” for grounding connection.**

#### **6.4 - Welding circuit**

GSX 425 rectifier good performance depends on use of a Copper working cable, insulated, in optimal conditions, firmly fastened to its terminals, as short in length as possible and compatible with considered applications. Also connections to work piece or to working bench and “negative” terminal should be well fastened.

No matter its total length (which should always be as short as possible) and no matter the welding current in use, the diameter of working cable should correspond to maximum current GSX 425 rectifier can supply at 60% duty cycle.

Electrical resistance of welding circuit causes tension dropping allied to internal dropping (natural of rectifier itself) generating reduction in arc tension and maximum current available, making arc unstable.

#### **7 - Operation**

After connecting GSX 425 to mains and properly connecting electrode-holder and working cable:

- 1 - Put on-off switch in “on” position.  
Exhauster engine starts rotating so providing necessary refrigeration air flow to the equipment.
- 2 - Pre-adjust welding current using crank on front panel. By rotating crank clock-wise, current value increases; by rotating it in the opposite direction, current value decreases.

#### **Attention!**

Welding parameters adjustment will basically depend on electrode material and diameter, on work piece width and welding position.

- 3 - Proceed to arc ignition and, if necessary, adjust current.

#### **8 - Maintenance**

Under normal operation conditions, GSX

425 rectifier does not require special maintenance. It is enough to clean it internally, once in a month, using dry and oil free compressed air at low pressure.

After this procedure, check electrical connections and components fastening. Check as well eventual damage signs on electrical wiring and cables, including working cable and other insulating materials. Replace them in case of any damage signs.

When overloaded due to lack of refrigeration or working conditions not projected by Eutectic do Brasil, rectifying bridge can be damaged by opening or short-circuit. Under these circumstances, no-load voltage is inferior to recommended value and rectifying bridge should be replaced.

#### **9 - Repair**

In order to assure optimum performance of an Eutectic equipment, only original spare parts, supplied or approved by Eutectic do Brasil, should be used. Utilization of non-original or non-approved parts cancels the warranty.

**10 - Electrical diagram**

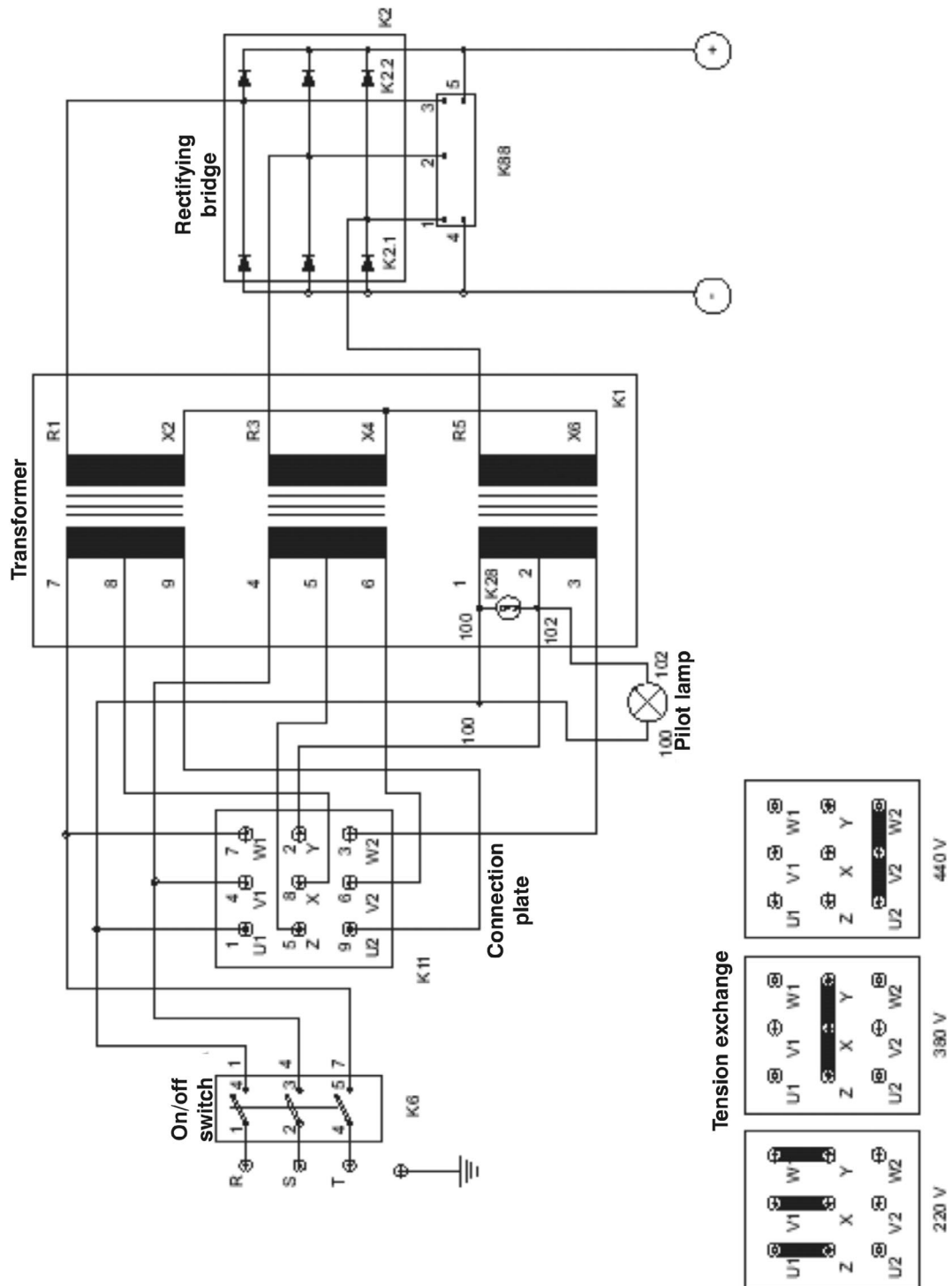



**11 - Spare parts**

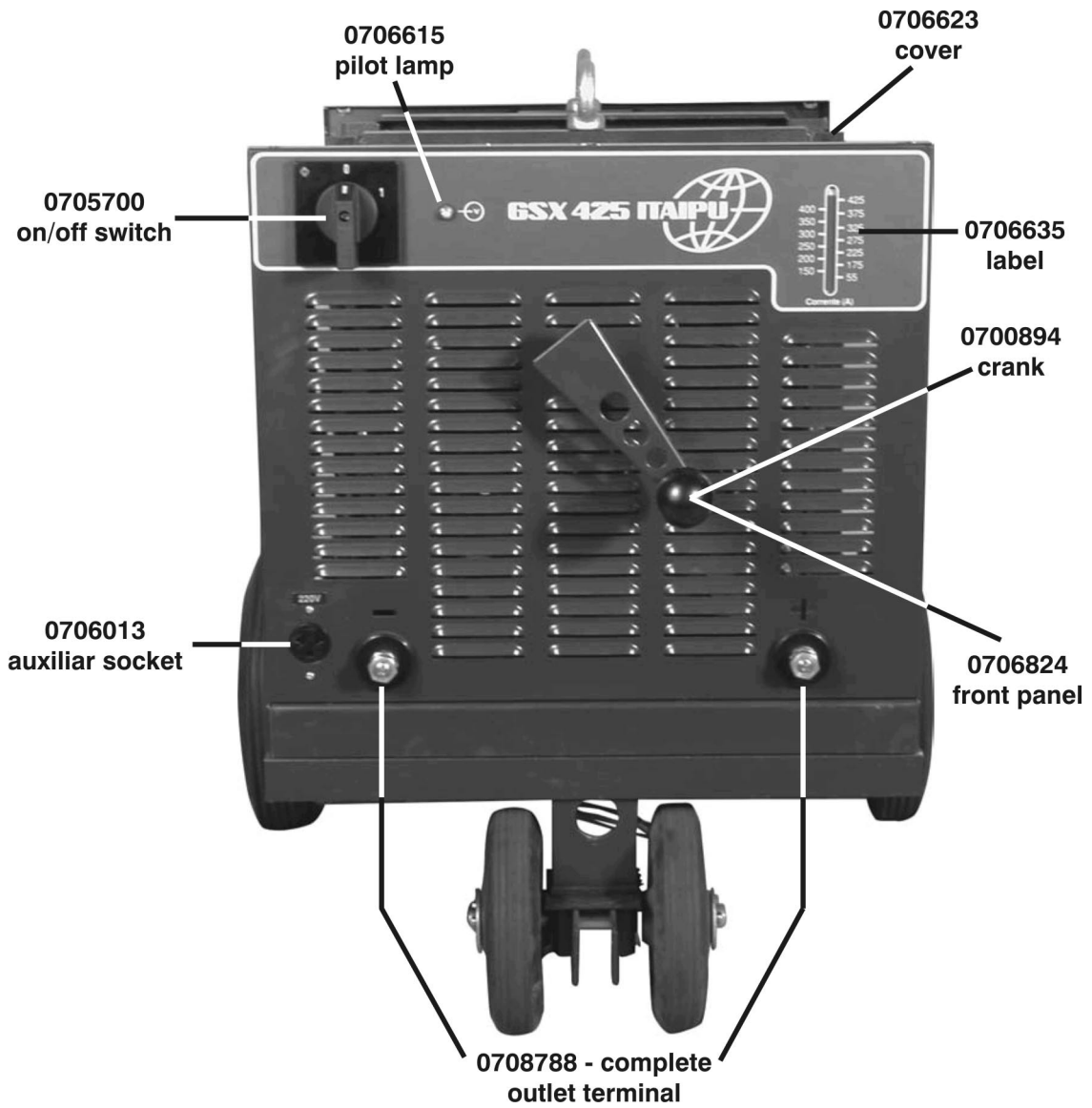

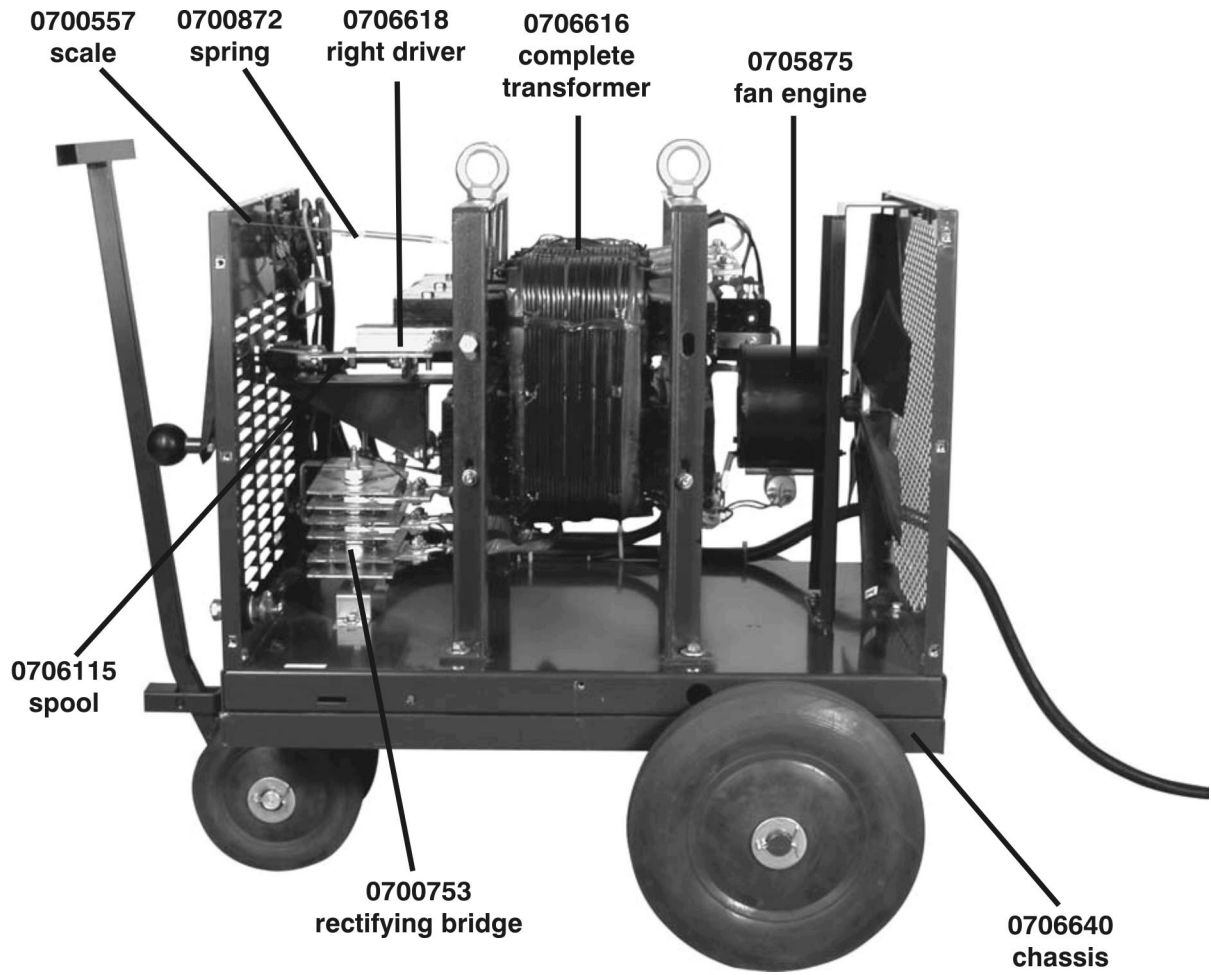

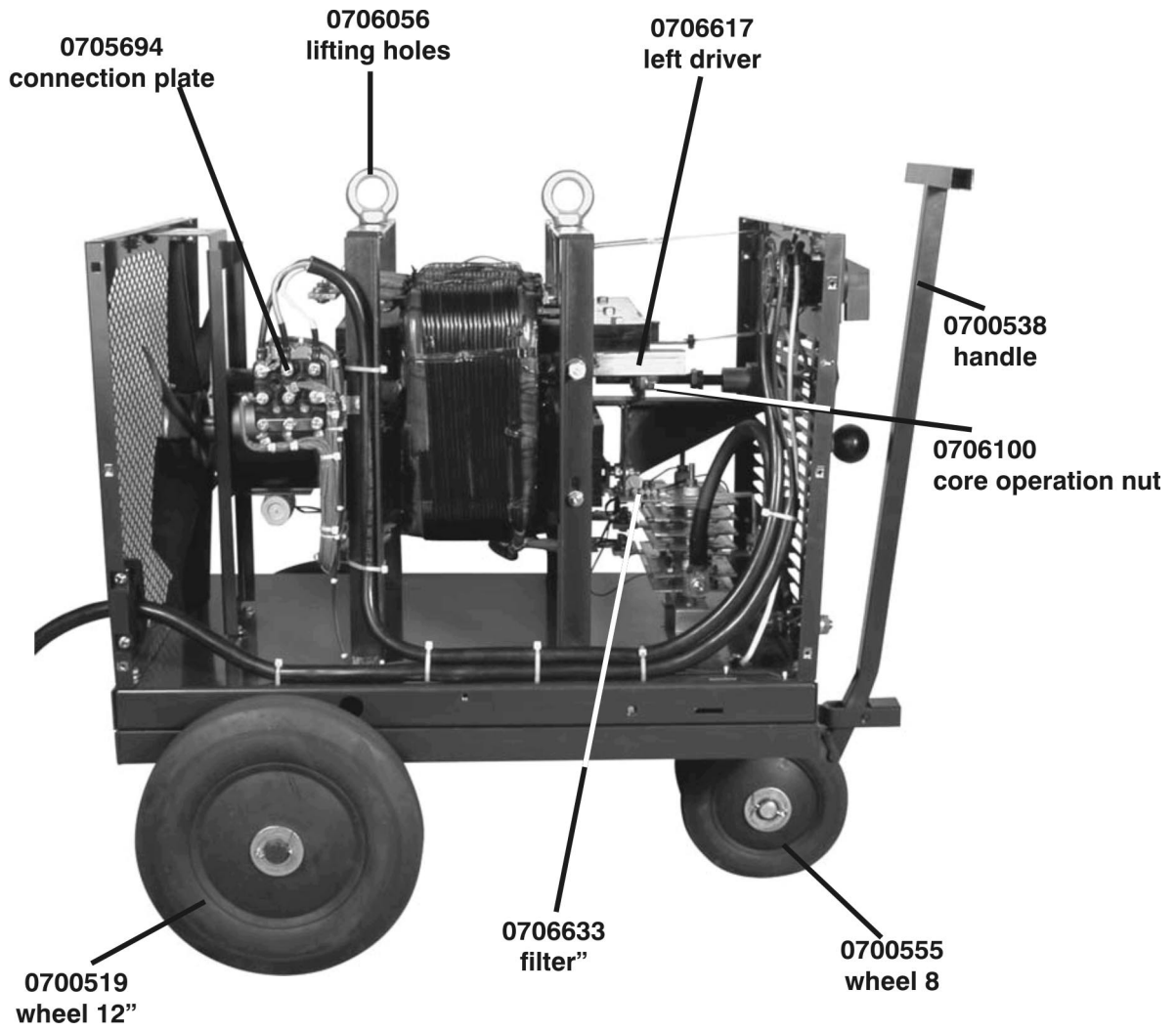

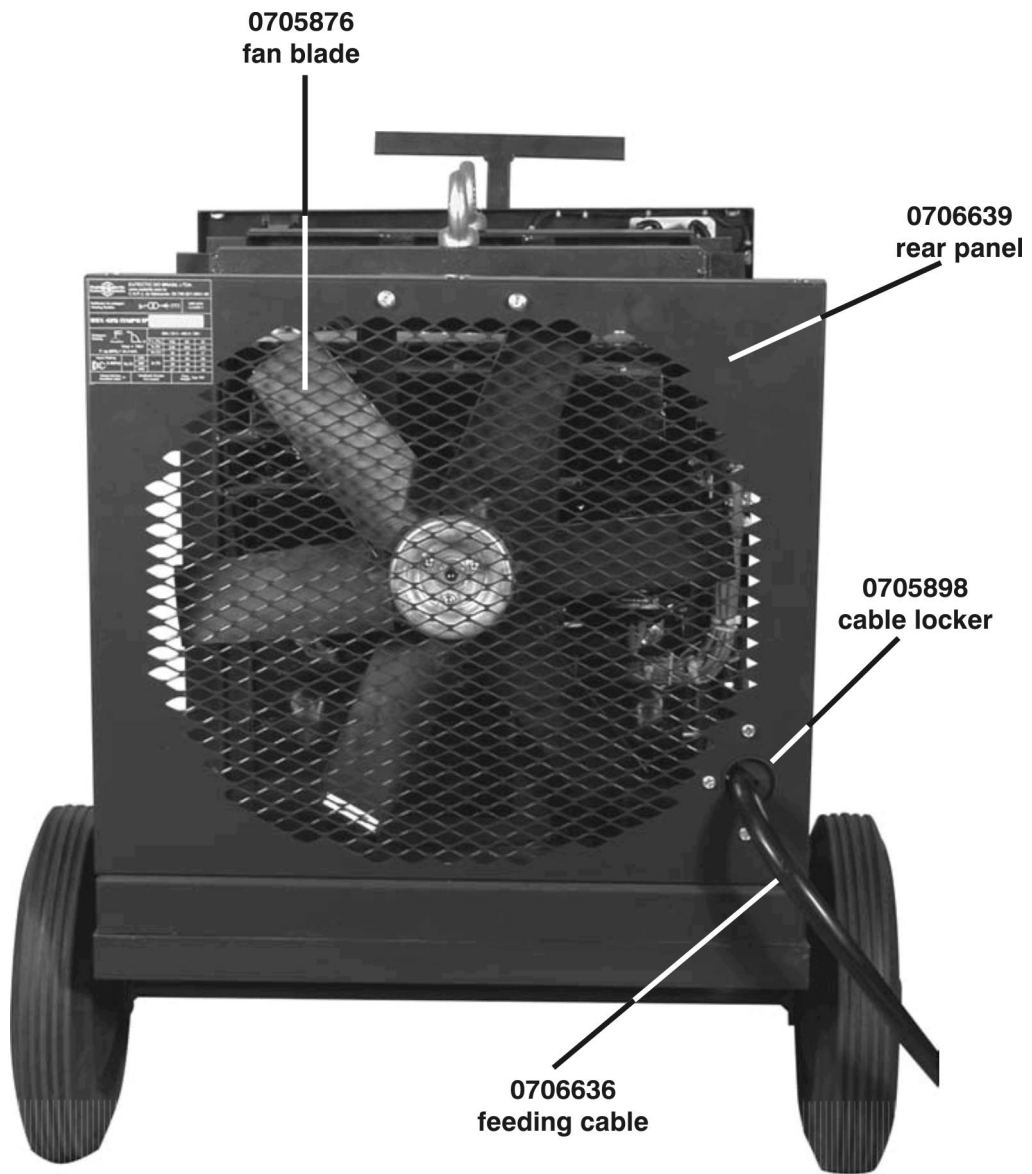



**11.1 - Transformer - front view**

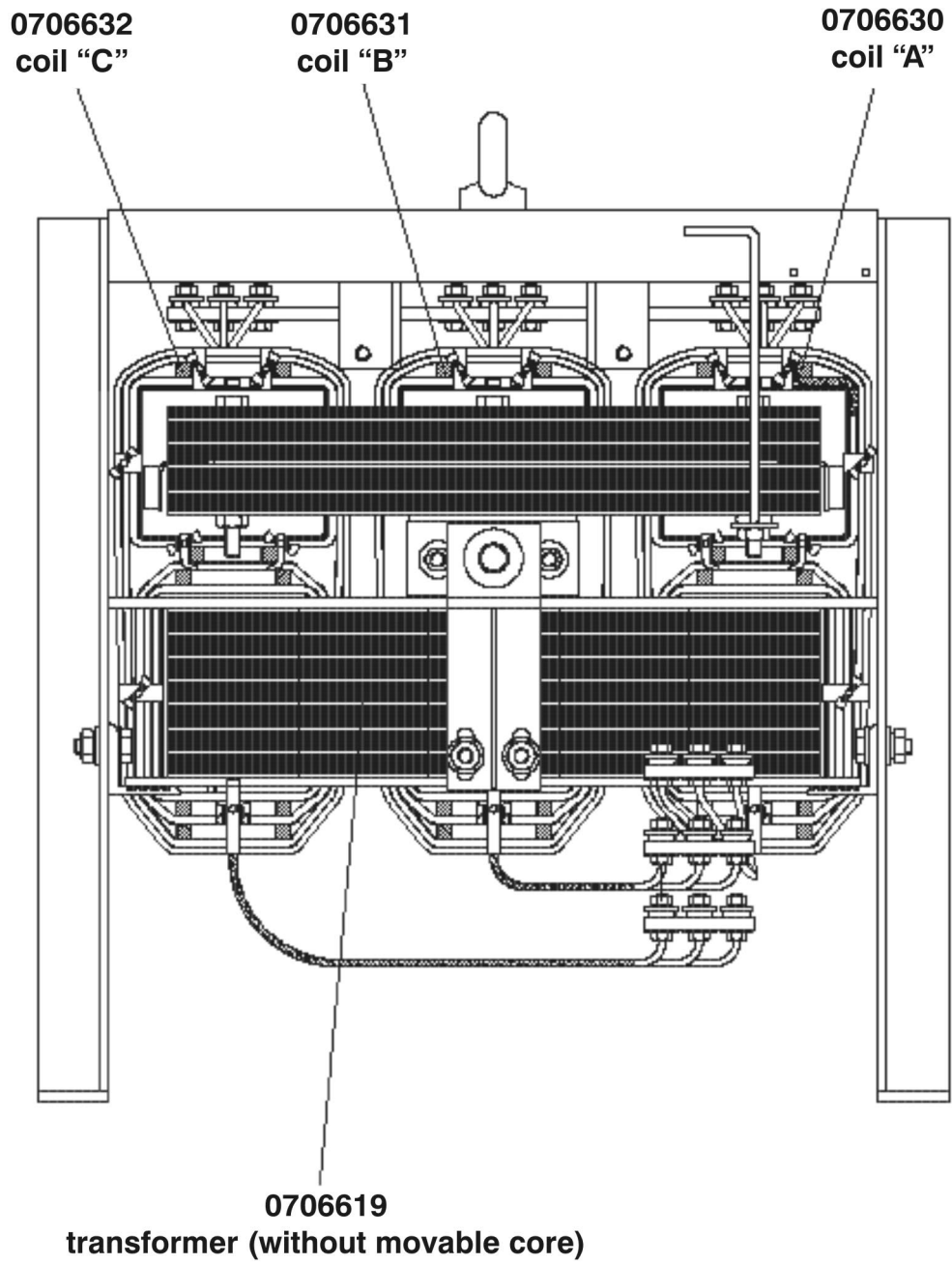



**EUTECTIC DO BRASIL LTDA.**

R. Ferreira Viana, 146 - CEP 04761-010 - Toll Free: 0800 7034370 - Tel.: 0(XX)11-2131-2300 - Fax: 0(XX)11-2131-2393 - São Paulo - SP  
• BELO HORIZONTE: Tel.: 0(XX)31-2191-4488 - FAX: 0(XX)31-2191-4491 • PORTO ALEGRE: Tel.: 0(XX)51-3241-6070 - FAX: 0(XX)51-3241-6070  
• RIBEIRÃO PRETO: 0(XX)16-624-6486 - FAX: 0(XX)16-624-6116 • RECIFE: Tel.: 0(XX)81-3327-2197 - FAX: 0(XX)81-3327-6661  
• CURITIBA: Tel.: 0(XX)41-339-6207 - FAX: 0(XX)41-339-6234 • SALVADOR: Tel.: 0(XX)71-374-6691 - FAX: 0(XX)71-374-6703

**Internet: <http://www.eutectic.com.br>**